

# KINDNESS 101

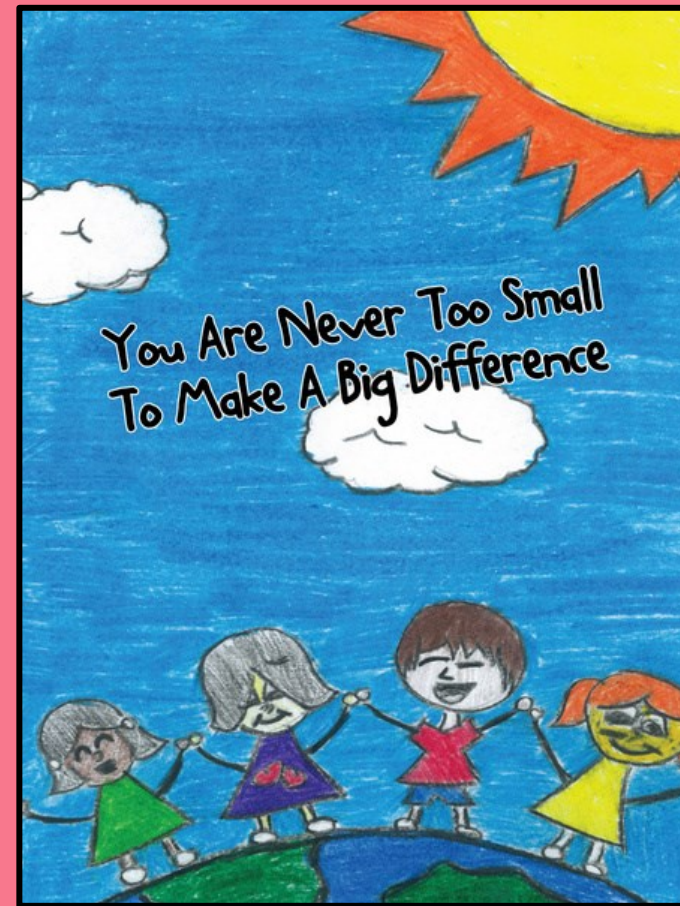

**BETH ROSENTHAL DAVIS, ED.S, NBCT**

# ● ABOUT ME ●



ELEMENTARY TEACHER 15 YEARS

FOUNDER KIDS 4 KIDS INC CHARITY IN 1997



OWNER/DIRECTOR KIDS FOR KIDS ACADEMY 20 YEARS

NAEYC LEGACY SCHOOL ACCREDITED SINCE 2005



AUTHOR & CONFERENCE PRESENTER

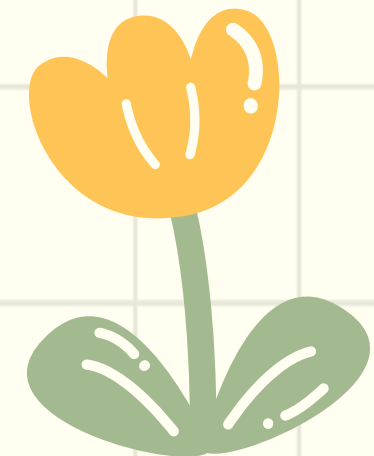
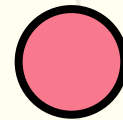
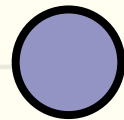
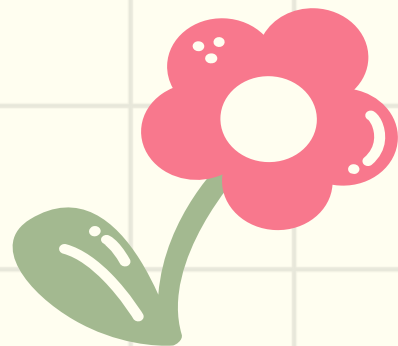





Cambridge Dictionary says, “Kindness is the quality of being generous, helpful, and caring about other people, or an act showing this quality.”

Aristotle defined kindness as, “Helpfulness towards someone in need, not in return for anything, nor for the advantage of the helper himself, but for that of the person helped.” Here we can see two important highlights of kindness; it’s always made to serve someone else, and nothing should be expected in return.



## Why does kindness matter?



There are many benefits to kindness. According to scientists, when we practice kindness, our body produces a dose of a hormone called oxytocin which is one of the so-called “feel good” hormones, meaning we are biologically programmed to take care of others. Imagine all the benefits that could come from this “feel good” sensation in the classroom!



## Encouragement to keep learning



Adding all these benefits together, it's safe to say that kindness promotes an environment that is safe and engaging enough for students to feel motivated to keep learning and that there's enough empathy for their peers to accept their mistakes and even learn from them, helping each other again and again.



## Benefits of kindness in the classroom



- **Empathy:** Since kindness is based on serving someone else, when we are kind, this helps us develop and create a more empathetic environment, which means people will be nicer and more respectful to each other.
- **Well-being:** Studies published in the Random Acts of Kindness Foundation show that there are several biological benefits of kindness that affect our overall well-being.



## Additional Benefits of kindness in the classroom



- According to scientific research, some of these benefits are an increase in energy levels, high doses of “feel good” hormones like oxytocin, endorphin and serotonin as well as lowered anxiety and stress levels, pain and even depression.
- This doesn't affect only the two people in making and receiving an act of kindness. According to the author Simon Sinek in *The Scientific Power of Kindness*, even people who witness an act of kindness get a dose of oxytocin. This means that bringing acts of kindness as a culture in the classroom can create a safer place where students and teachers feel good more often and are contagiously motivated to be kind to each other.

I believe kindness is learned behavior



Grandpa Ben survived on the kindness of others as a child. He instilled the importance of being kind to my mom and my mom made it her priority to teach me to be kind at an early age by performing acts of kindness... *Tzekah*.



*I dedicate this presentation to Grandpa Ben*



From my first year as a teacher 35 years ago, teaching kindness has been important to me.

# NEIGHBORS

The Miami Herald

THURSDAY  
MAY 16, 1991

## PILES OF PENNIES TO HELP HUNGRY

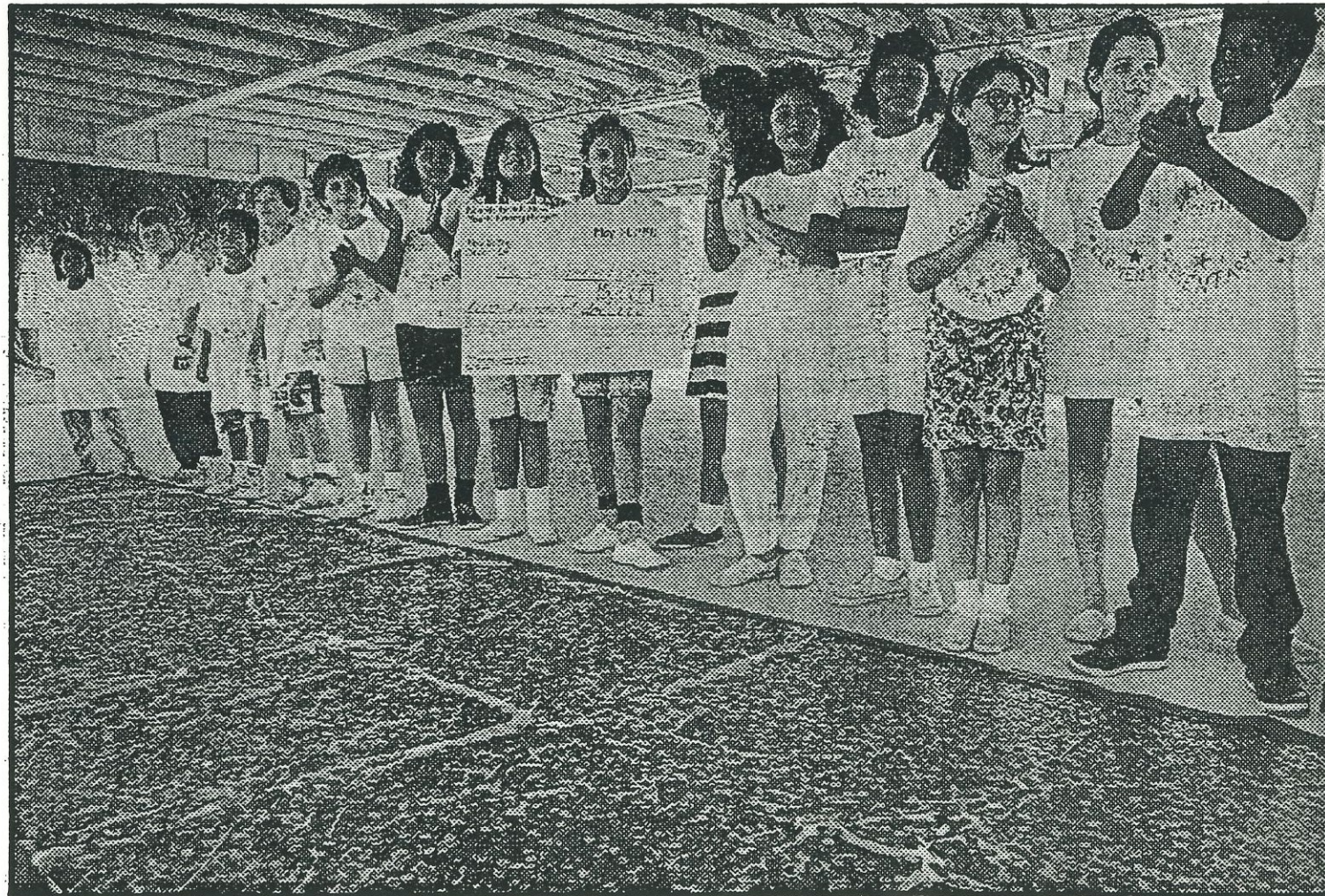

RANDY BAZEMORE / Miami Herald Staff

The Youth Ending Hunger Club at North Beach Elementary School, 4100 Prairie Ave., displays some of the 50,000 pennies it collected to represent the 35,000 people who die each day from hunger. The group, which had sought to collect 35,000 pennies, will donate the money to charity.

In my first year, I had a Youth Ending Hunger Club. The club taught kids that not everyone has food and the awareness of hunger worldwide. The students collected 50,000 pennies to raise awareness of how many people died of hunger each day in 1991. The kids learned they can help others with something as simple as pennies. The money was donated to a local soup food pantry.



# South Pointe Students Present 800 Meals to Camillus House

Students at South Pointe Elementary School presented more than 800 bagged meals Wednesday morning to representatives of Camillus house to feed Dade's homeless. The presentation took place in the courtyard at

South Pointe, 1050 Fourth Street, Miami Beach. The effort included one bagged meal from each student, plus several from teachers. It was a project of the South Pointe Elementary

Youth Ending Hunger. More than 30 of Beth Rosenthal's students brought meals for Thanksgiving, and it made them feel so good, the whole school picked up on it.

The bags, decorated according to the imagination of each student, contained such staples as peanut butter sandwiches, fruit and juice - in addition to the students' good wishes.



Over the years thousands of bags were decorated and filled with love my students and delivered to the homeless of Miami.

Vol. 2, No. 15

# T·H·E COURIER

December 15, 199

"Your News, Your Newspaper"

## Making A Difference

COURIER STAFF PHOTO BY HAYNE FLEISSE

A PEANUT BUTTER and jelly sandwich doesn't sound like much of a holiday meal, but if you're hungry and homeless and have nothing else, it's the same as a feast. The children at Jack Gordon Elementary School in Country Walk understand that and are trying to help. Second-grader Zachary Zinkand (left) and Danny Wells are making a difference by makin sandwiches which will be given to the needy. FOR MORE, SEE PAGE 10

10 THE COURIER

## SPOTLIGHT

December 15, 1995

# HELPING ANYWAY THEY CAN

LESSONS LEARNED AT Christmastime last a lifetime. The Jack Gordon Elementary School students you see on this page are learning the most important lesson of all - how to give. The children from the Country Walk area spent their day last Friday making peanut butter and jelly sandwiches to distribute to the needy of South Dade during the coming days. The children put together 1,600 bagged meals, including the sandwich, fruit and cookies, many of which are pictured at right. Below, "Making A Difference Day" put Kristen Burton, Ashley Blanton and Thatiana Arrave (left to right) to work, spreading peanut butter on bread.

Next, I started clubs called Kids for Kids. They met weekly to do project to help others. One project found students decorating brown bags for the homeless and filling them with peanut butter sandwiches and other goodies donated by students.



## Why Was Kids 4 Kids Founded?

Think back to the first day of elementary school that you can remember....Can you remember having a new box of crayons with sharp points? Can you remember what they smelled like?

My experience as an educator on the first day of school....





# About Kids 4 Kids

Kids 4 Kids empowers children to create a better world through kindness. We're dedicated to providing essential resources, support, and opportunities to children facing various challenges. We believe that every child deserves a chance to thrive, regardless of their circumstances.





After the mystery schoolwide illness prohibited our peanut butter sandwich assembly line, our annual sandwich project was halted. We shifted our gears to our Backpack program that that has provided over 95,000 backpacks for kids who needed them. Those backpacks evened the playing field for foster kids, homeless kids and children of migrant farmworkers.

We won a national grant competition and the \$12,000 prize money from this grant was used to start **Kids 4 Kids Inc.** a 501c3 nonprofit organization.

The mission of Kids 4 Kids is to teach children that they can change the world through their acts of kindness while providing goods and services to children in need.



**Kids 4 Kids Inc.** has no paid staff. 100% of monies raised supports our initiatives in the community.

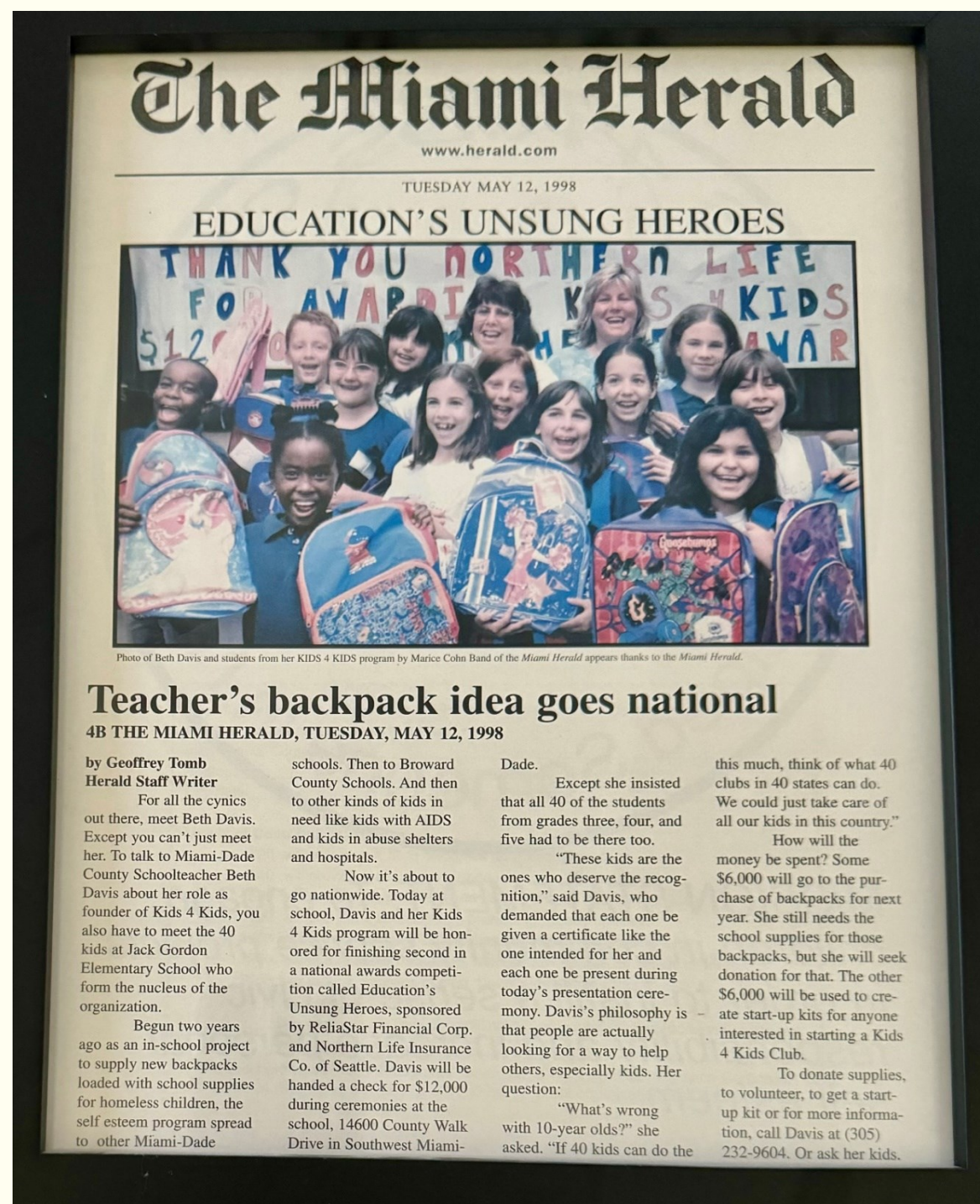



**CLICK THIS IMAGE FOR VIDEO**



## **FILL-A-BACKPACK CAMPAIGN**

The FILL-A-BACKPACK CAMPAIGN is Kids 4 Kids' primary initiative, where volunteers fill thousands of backpacks with school supplies during the summer. These backpacks are then distributed to children in migrant camps and shelters on the first Saturday of August. The experience teaches volunteers about the ongoing challenges many children face, including homelessness, abuse, and illness.



At Kids 4 Kids, we believe every child deserves the tools and support to succeed. Since 1997, we've been dedicated to providing educational resources, financial assistance, and disaster relief to children and families in need.



# OTHER PROJECTS

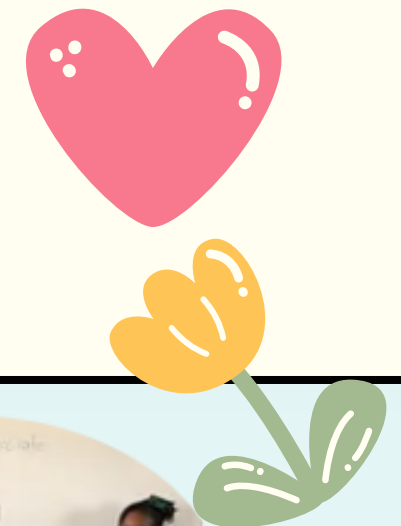
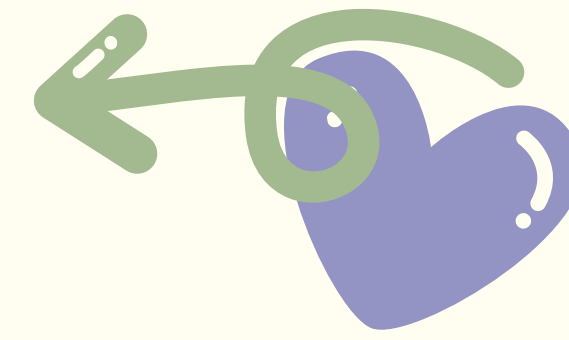

## SUPPORTING SICK CHILDREN

Kids 4 Kids also raises money to assist families whose children have been diagnosed with illnesses. 100% of all donations earmarked for children battling illnesses are given to families during this difficult time. Funds are given to families to assist with medical bills and loss of income when families have to miss work to take care of a sick child.

**\$140,000 RAISED**



## BOOK RECYCLING & DISTRIBUTION

Kids 4 Kids Book Recycling and Distribution program encourages kids and members of the community to donate used and new books for children who could not afford books of their own.

Kids 4 Kids has collected and distributed thousands of books over the years.

**THOUSANDS OF BOOKS DONATED**



## HURRICANE RELIEF EFFORTS

After Hurricane Dorian, Kids 4 Kids in collaboration with families from Kids For Kids Academy, Miami Dade County Schools, Neighbors 4 Neighbors, South Florida Roofers, and Catering the Event we helped families in Grand Bahama. Our Community raised money and also donated 9 containers filled with school furniture, whiteboards, roofing materials, and boxes of food for families during their time of crisis.

**\$250,000 RAISED**

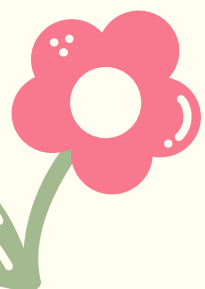



## OTHER PROJECTS

Kids 4 Kids organizes activities throughout the year to engage children in helping others. During Valentine's Day and Halloween, they create treat bags and cards for children in shelters, hospitals, and those experiencing homelessness. They also collect gift cards for Thanksgiving and the December holidays to provide support to families in need.

**KIDS AT KIDS FOR KIDS ACADEMY DONATE BAGS OF CANDY.**

**STUDENTS DECORATE & FILL 200 BAGS EACH YEAR SO THAT HOMELESS KIDS CAN ENJOY THE SIMPLE PLEASURES OF A BAG OF CANDY ON HALLOWEEN.**

**STUDENTS ALSO DONATE GENTLY USED HALLOWEEN COSTUMES THAT ARE ALSO DELIVERED TO THE SHELTER.**





# KINDNESS 101



## Weekly Kindness Videos



 Kindness 101 with Steve Hartman  
CBS Mornings · Playlist

[Click Here For The Kindness 101 by Steve Harman Playlist](#)

At Kids For Kids Academy, part of the Elementary curriculum is using the 40 Steve Hartman Kindness 101 videos, one a week as part of the morning routine. Teachers school-wide use the same concepts each week, starting with #1 on Steve Hartman's Kindness 101 YouTube Playlist.

Each video is only 5-6 minutes long, and the use of his children in the segments makes it relevant for Elementary kids. After the video, the class discusses the definition of each kindness concept.

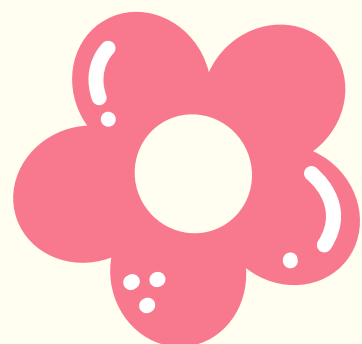
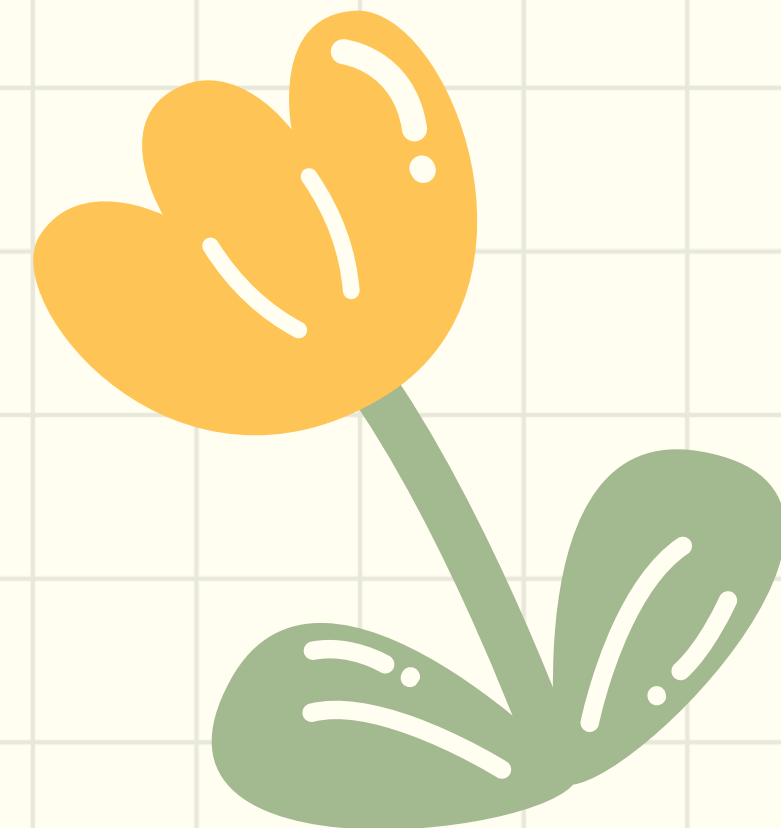
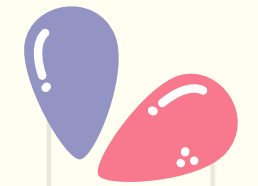



## Kindness 101 with Steve Hartman









CBS Mornings

42 videos 195,889 views Updated 4 days ago



▶ Play all

↻ Shuffle

- 1  Kindness 101: Fifth graders take action after hearing elderly couple's story  
CBS Mornings • 24K views • 4 days ago
- 2  Kindness 101: a woman's journey to find companionship for a lonely goose  
CBS Mornings • 5.6K views • 11 days ago
- 3  Kindness 101: Reciprocity  
CBS Mornings • 23K views • 4 months ago
- 4  Kindness 101: Appreciation  
CBS Mornings • 14K views • 4 months ago
- 5  Kindness 101: A look at leadership  
CBS Mornings • 13K views • 4 months ago
- 6  Kindness 101: Modesty  
CBS Mornings • 16K views • 4 months ago
- 7  Kindness 101: Purpose  
CBS Mornings • 23K views • 5 months ago
- 8  Kindness 101: Altruism  
CBS Mornings • 12K views • 5 months ago

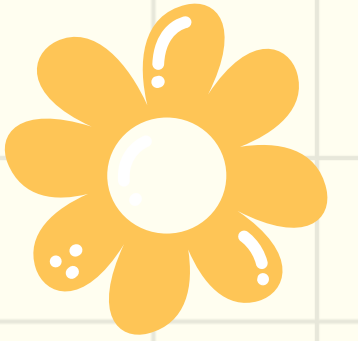

**HERE IS PART OF STEVE HARTMAN'S PLAYLIST**

**YOU CAN ACCESS THIS PLAYLIST ON THE**

**KIDS 4 KIDS WEBSITE**

**OR**

**GO TO YOUTUBE**

**AND SEARCH KINDNESS 101**

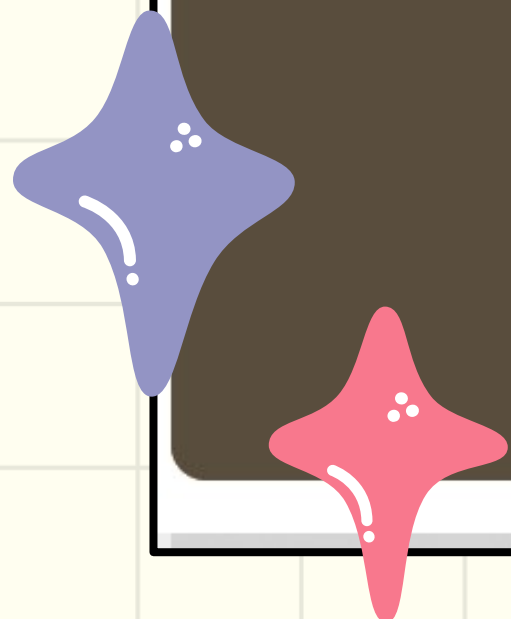
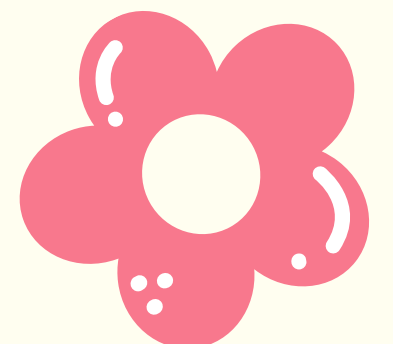
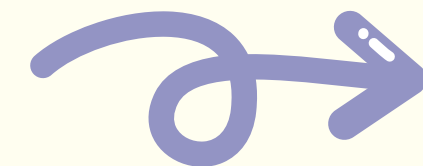



# KINDNESS 101

## A LESSON IN FRIENDSHIP



[CLICK THIS IMAGE FOR VIDEO](#)



# Weekly Kindness Lessons At Kids For Kids Academy



Kindness 101 Topic: Leadership



## Kindness 101: A look at leadership

Our Kindness 101 lesson was about leadership. Students saw a beautiful video about a middle school boy...

[Read More](#)



Kindness 101 Topic 2: Appreciation



## Kindness 101 - Week 2: Appreciation

APPRECIATION: This word means recognizing the value of someone or something. During this week we covered...

[Read More](#)



Kindness 101 Topic 1: Reciprocity

## Kindness 101 - Week 1: Reciprocity

RECIPROCITY. This word means to share kindness with others who have been kind.. Our elementary students...

[Read More](#)



# Weekly Kindness Lessons At Kids For Kids Academy



## Kindness 101: Courage

"Courage." Within this trait, first graders talked about having conviction, being a leader, ...

[Read More](#)

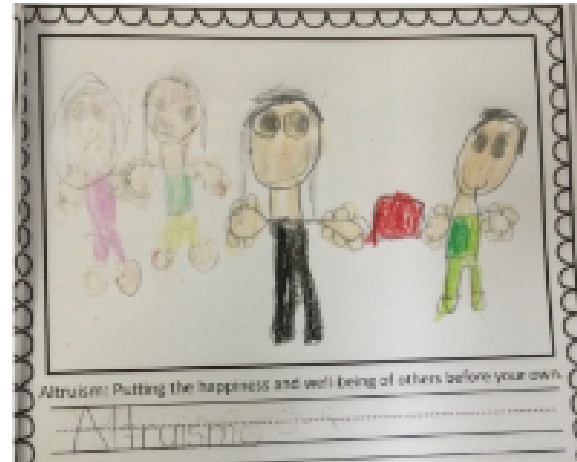

Altruism: kindergarten students discussed one way of thinking about someone's happiness before their own would be to donate some of their toys to children who need them. This is an example of being altruistic.

## Kindness 101: Altruism

Our Kindergarten kids learned about Altruism. They saw the video and the children discussed that one...

[Read More](#)



Empathy: students watched a video of a four-year-old who felt empathy for the homeless. They decided to color and pass out cards with kind messages to people they saw doing kind things.



## Kindness 101: Empathy

First and Second Grade students learned and practiced the trait of empathy. They watched and discussed...

[Read More](#)

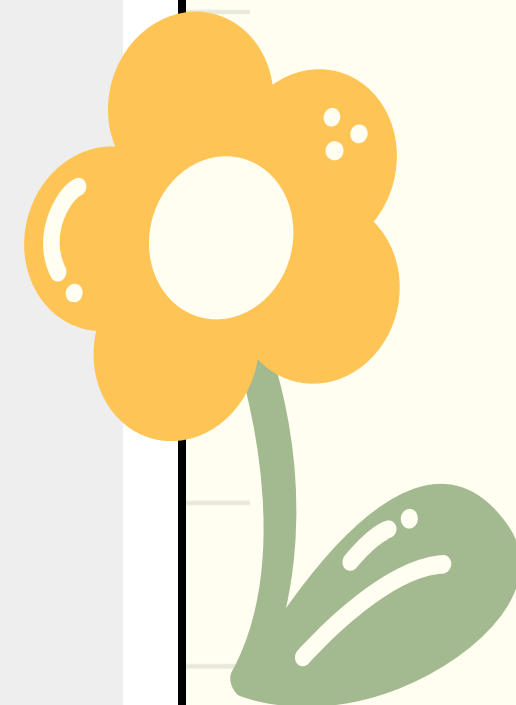
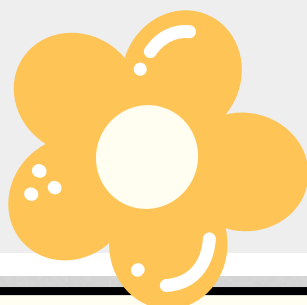



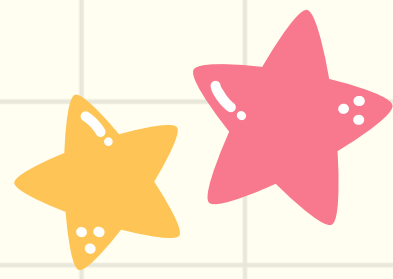

# KINDNESS JOURNAL



After the video, the class discusses the definition of each kindness concept. The definitions are found in the journal I created, which can be found here.

**The journal pages follow the order of the Kindness 101 playlist, making it easy to track student progress and reflection.**

Throughout the week, students have a chance to write about the segment in the journal and draw pictures. If you do not wish to copy the journal, teachers can make one for themselves and write the Kindness concept with the definition of the word on the board, and students can transfer it to a dedicated Kindness Journal composition book.

**DOWNLOAD FREE ON THE KIDS 4 KIDS WEBSITE**

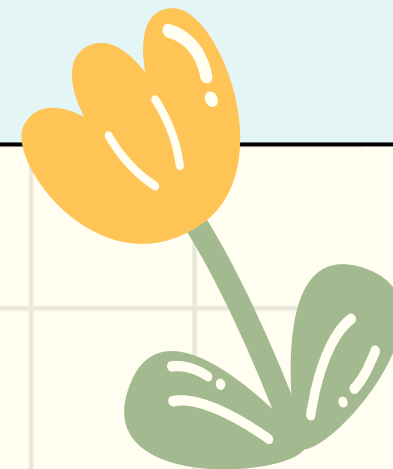
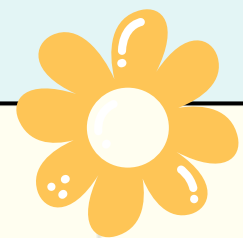
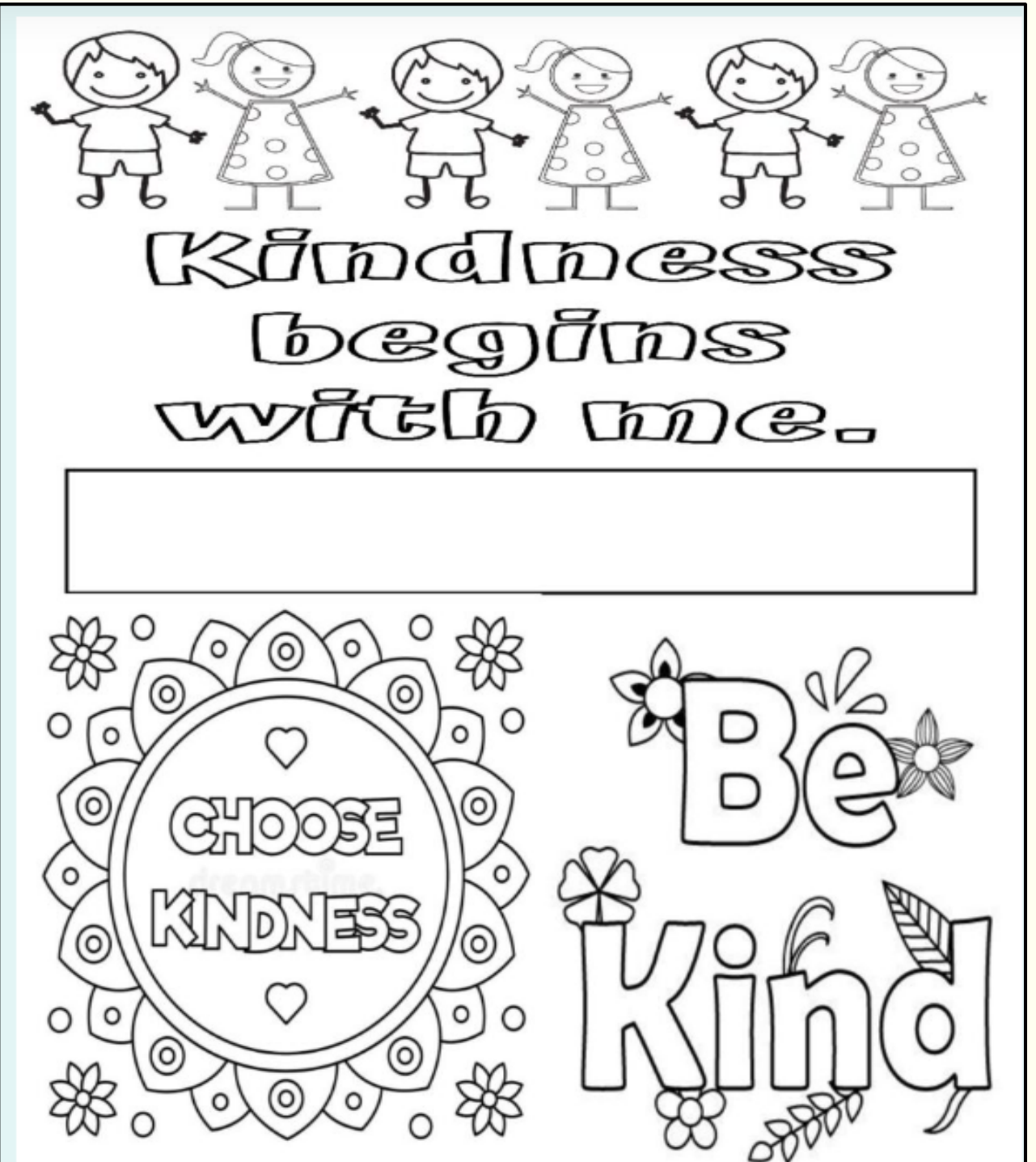



# OTHER THINGS YOUR STUDENTS CAN DO TO HELP OTHERS

**BRING IN CANDY AND FILL BAGS FOR HOMELESS KIDS FOR HALLOWEEN.**

**MAKE GET-WELL CARDS FOR KIDS IN LOCAL HOSPITALS.**

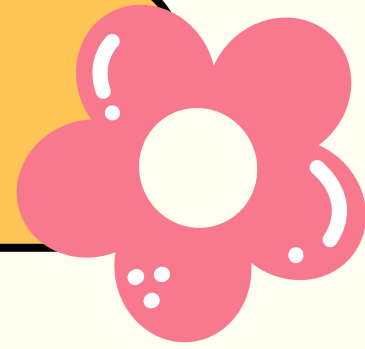

**FILL SHOEBOXES WITH DOLLAR STORE SNACKS AND TOILETRIES TO BE SENT TO SOLDIERS SERVING OUR COUNTRY.**

**MAKE VALENTINE CARDS OR CRAFTS FOR SENIOR CITIZENS OR FOSTER KIDS.**

**COLLECT NEW TOYS FOR LOCAL HOLIDAY TOY DRIVES OR FOR NEEDY KIDS AT YOUR CENTER**

**COLLECT \$5 GROCERY GIFT CARDS AND GIVE TO FAMILIES IN NEED TO SHOP FOR THEIR OWN THANKSGIVING WISHES INSTEAD OF DOING CANNED FOOD DRIVES**

**HAVE STUDENTS DESIGN AND PASS OUT THEIR OWN KINDNESS CARDS**





**BE KIND BOOKMARK  
COLORING TEMPLATES AND  
MOTIVATIONAL COLORING  
PAGES TO COLOR FOR KIDS  
IN HOSPITALS  
AVAILABLE FREE FOR  
DOWNLOAD ON THE  
KIDS 4 KIDS WEBSITE**



**HERE ARE  
SAMPLES OF  
THE 60-PAGE  
COLORING  
BOOK**

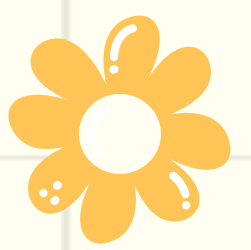
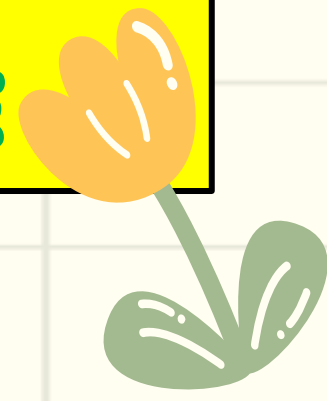
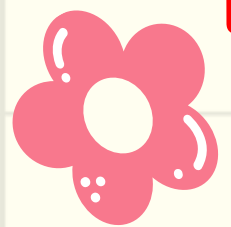



# SAMPLE KINDNESS CARDS

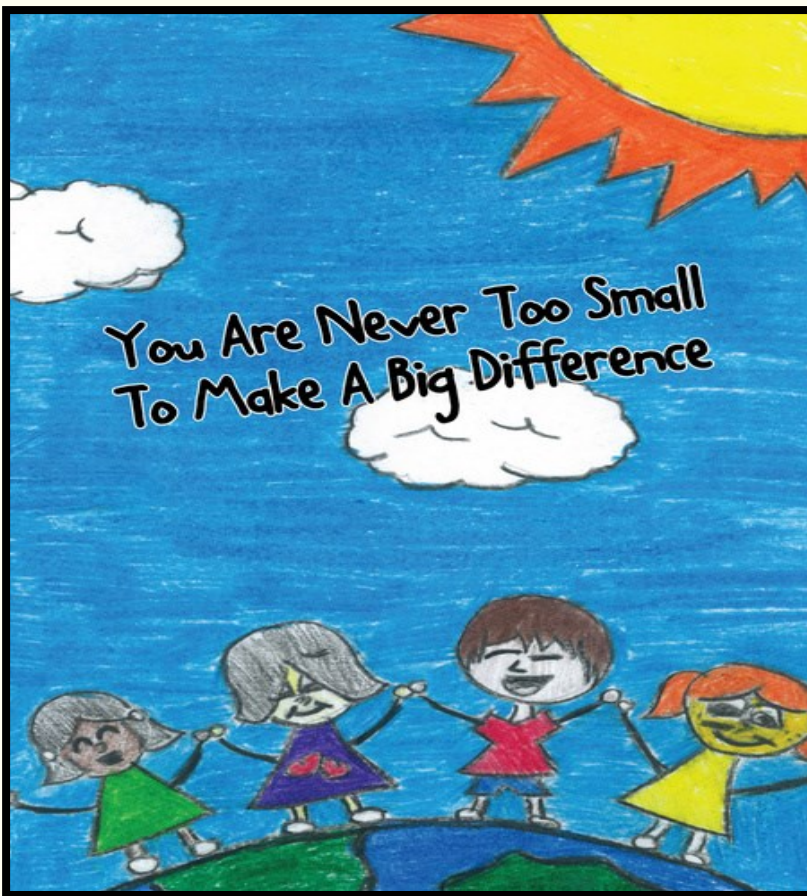
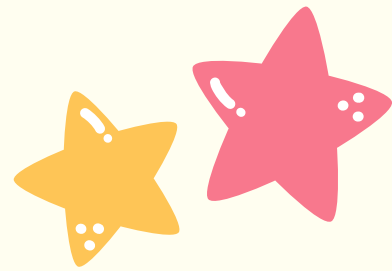

Grab Your **FREE** Copy Of "You Are Never Too Small To Make A Big Difference" Today!

[Click here to download now](#)

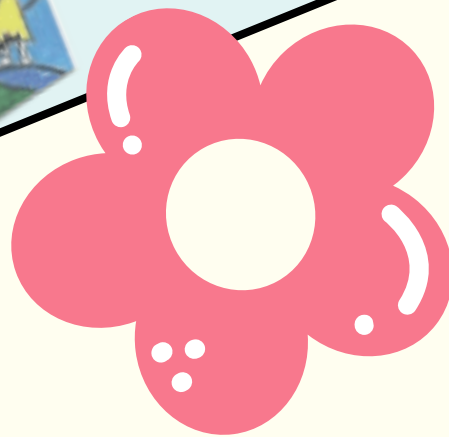
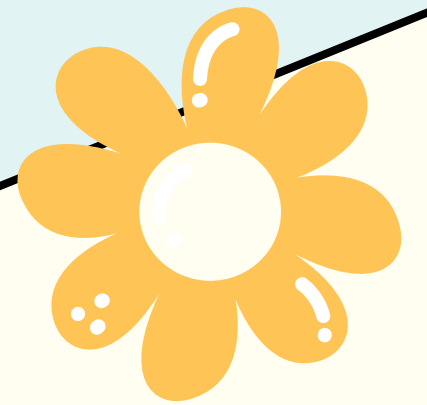

You just performed a random act of kindness. I noticed and want to thank you for helping make our community and our world a better place.

Please enjoy the artwork on the other side, created by a child, and pass this card along to someone you see performing a random act of kindness.

Usted realizó un acto de bondad. Noté y quiero agradecerle por ayudar a hacer nuestra comunidad y nuestro mundo un lugar mejor.

Por favor disfrute ilustraciones al reverso, creado por un niño, y pase esta tarjeta a alguien que usted vea realizar un acto de bondad.





**WHAT ARE WAYS YOUR STUDENTS SHOW KINDNESS TOWARD OTHERS?  
EMAIL PHOTOS AND CAPTIONS AND THEY WILL BE POSTED ON THE  
KINDNESS CHALLENGE FACEBOOK PAGE**

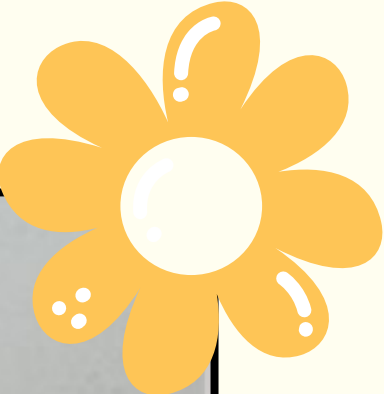



# TAKE THE KINDNESS PLEDGE







**TAKE THE KINDNESS PLEDGE:  
EACH SESSION PARTICIPANT  
WILL RECEIVE A FREE  
BRACELET AND KINDNESS  
CARD**

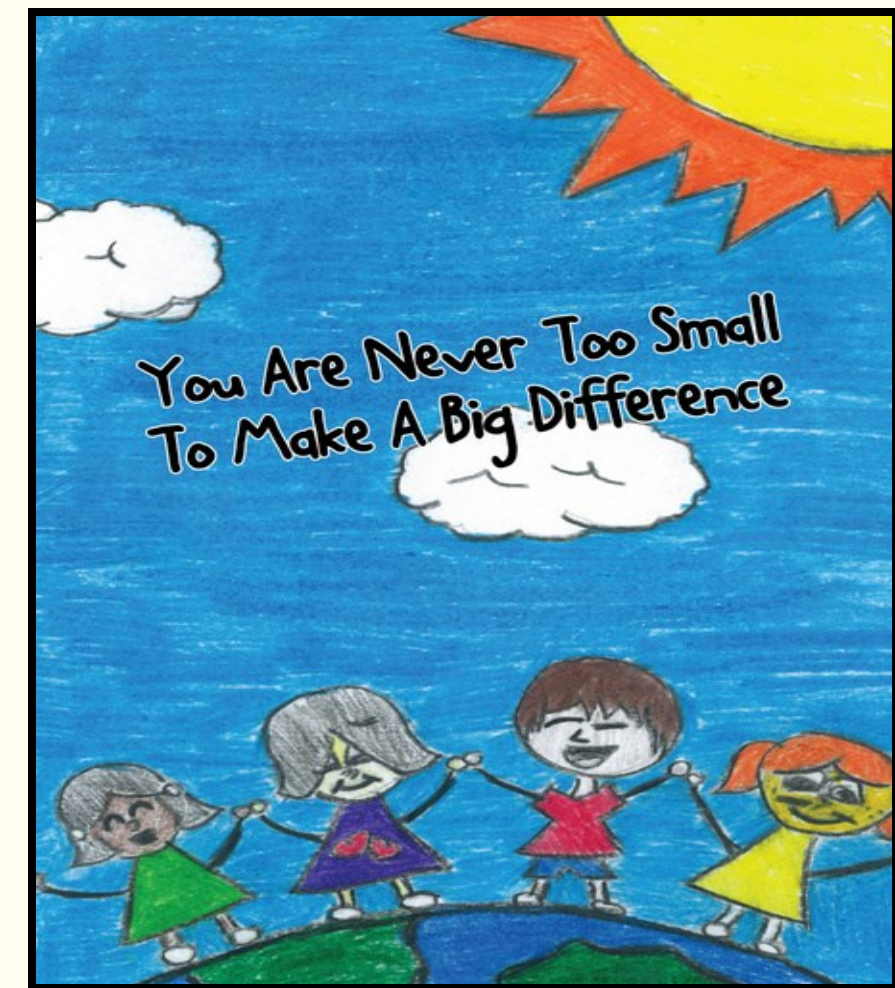

You just performed a random act of kindness. I noticed and want to thank you for helping make our community and our world a better place.

Please enjoy the artwork on the other side, created by a child, and pass this card along to someone you see performing a random act of kindness.

Usted realizó un acto de bondad. Noté y quiero agradecerle por ayudar a hacer nuestra comunidad y nuestro mundo un lugar mejor.

Por favor disfrute ilustraciones al reverso, creado por un niño, y pase esta tarjeta a alguien que usted vea realizar un acto de bondad.





# TAKE THE KINDNESS PLEDGE

Purchase, sell, and wear a Kindness Bracelets  
**PLEDGE TO BE KIND EVERY DAY!**

Bracelets are only \$2 each. 100% of bracelet sales to benefit our  
**FIELDTRIPS FOR FOSTER CARE Program** for Florida foster care agencies including



All donations are tax deductible.  
Kids 4 Kids Inc. is a 501c3

Donations can also be made at  
[www.kids4kids.org](http://www.kids4kids.org)



**ALL ORDERS INCLUDE FREE KINDESS CARDS**

**FIND OUT HOW YOUR BUSINESS OR ORGANIZATION CAN HELP.  
TEACHERS ACCESS OUR KINDNESS 101 CURRICULUM  
GO TO: [WWW.KIDS4KIDS.ORG](http://WWW.KIDS4KIDS.ORG)**

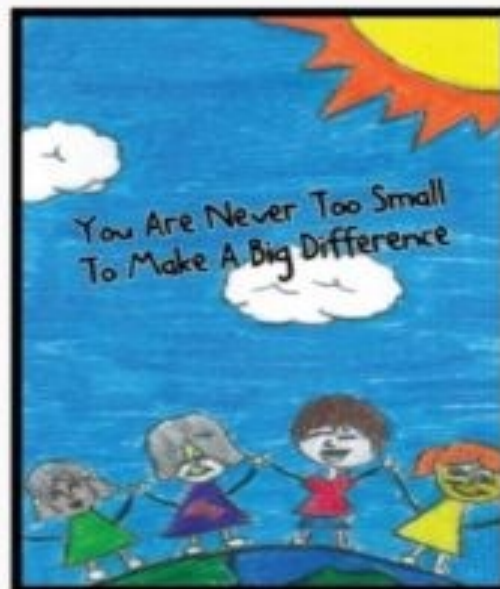

Scan to pay Steachkidskindness



Cash App

KIDS 4 KIDS, INC.  
[teachkidskindness@gmail.com](mailto:teachkidskindness@gmail.com)

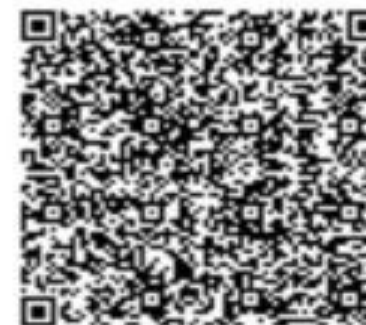

Zelle



PayPal





**BRACELETS AVAILABLE FOR STUDENTS AND STAFF**

**\$2 ADULT BRACELETS INCLUDE A FREE KINDNESS CARD**

**CHILD SIZES AVAILABLE FOR \$1.50**



# Have You Filled a Bucket Today?



A Guide to  
Daily Happiness  
for Kids



By Carol McCloud . . . Illustrated by David Messing

[CLICK THIS IMAGE FOR VIDEO](#)



Dear Parents,  
In school we read the book ***Have You Filled Your Bucket Today***. This heartwarming book encourages positive behavior as children see how rewarding it is to express daily kindness, appreciation, and love.

The book explains to children that we all carry an invisible bucket in which we keep our feeling about ourselves.

When our buckets are full, we are happy; when they are empty, we are sad. It is important to know that we can fill our own bucket and so can others. We fill buckets by saying nice things to the people around us. We fill buckets by doing nice things for people.

Please help your child fill the buckets of two friends on each of the given buckets. Help your child by having them dictate kind statements about their friends and help them to write them on the buckets. When finished, please help your child cut the buckets out and bring them back to school.

# SAMPLE "BUCKET FILLER" ACTIVITIES

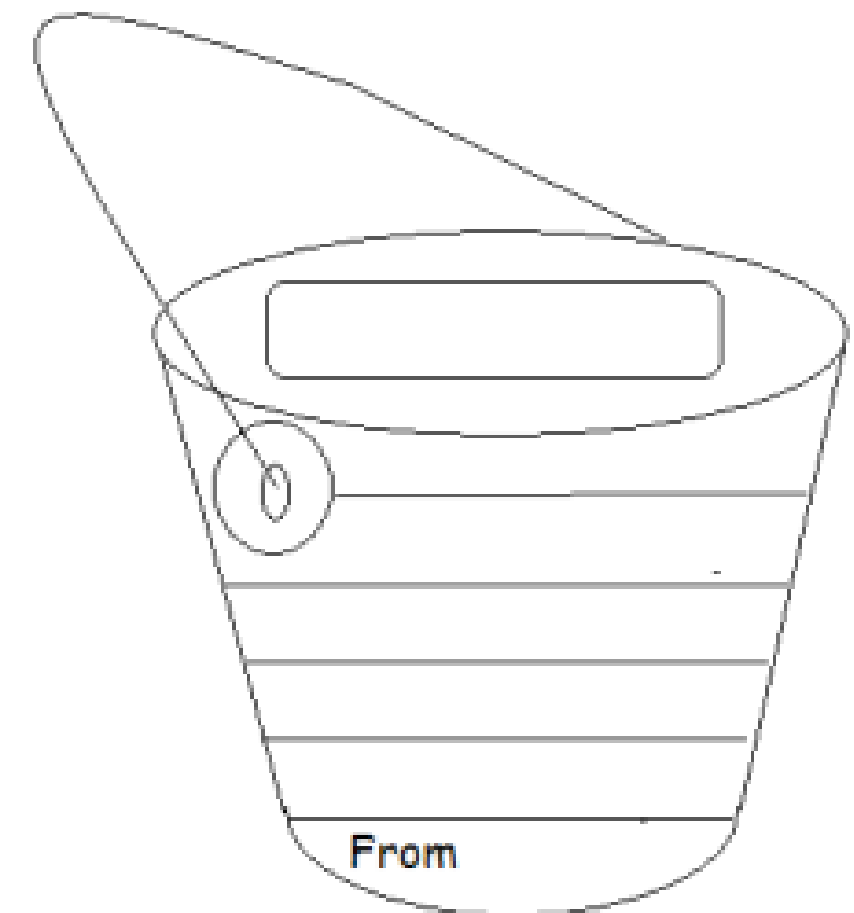
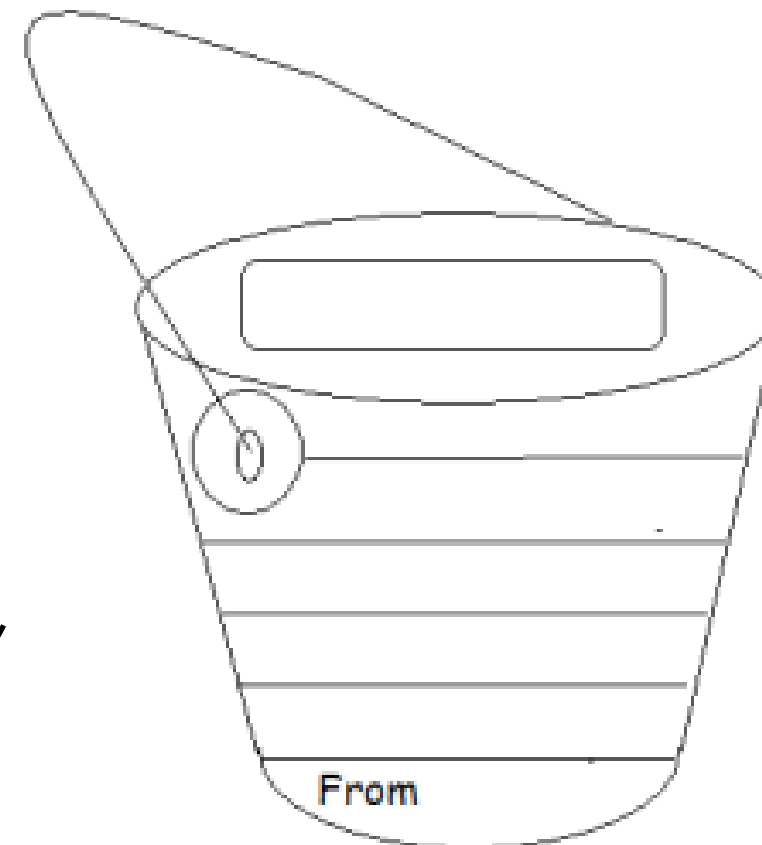



SOURCE:

# CREATING CONNECTIONS

bucket FILLING

bucket DIPPING

cheer up a sad friend	be a bully
help people who need it	exclude and run away
listen to others	ignore someone
care for animals	yell at others
show kindness	act mean

cut in line

say "I love..."

diver away

make friends

to play

Proud to be PRIMARY

SOURCE:

PROUD TO BE PRIMARY

A Bucket Filling Classroom...

CRAFTING CONNECTIONS

Looks like:	Sounds like:	Feels like:
<ul style="list-style-type: none"><li>• kids sharing supplies</li><li>• smiles ☺</li><li>• kids sticking up for a classmate who is being bullied</li><li>• kids writing nice notes to each other</li><li>• When someone spills their crayons, classmates help them pick them up</li><li>• kids working together</li></ul>	<ul style="list-style-type: none"><li>• compliments</li><li>• kind words</li><li>• friendly tone of voice (not sarcastic)</li><li>• saying "please" and "thank you"</li><li>• "Do you want to play with us?"</li><li>• "I like your..."</li><li>• "Do you need help?"</li></ul>	<ul style="list-style-type: none"><li>• happy</li><li>• <b>SAFE!</b></li><li>• helpful</li><li>• caring</li><li>• supportive</li><li>• friendly</li><li>• polite</li><li>• kind</li><li>• comfortable</li></ul>



# OTHER IDEAS....

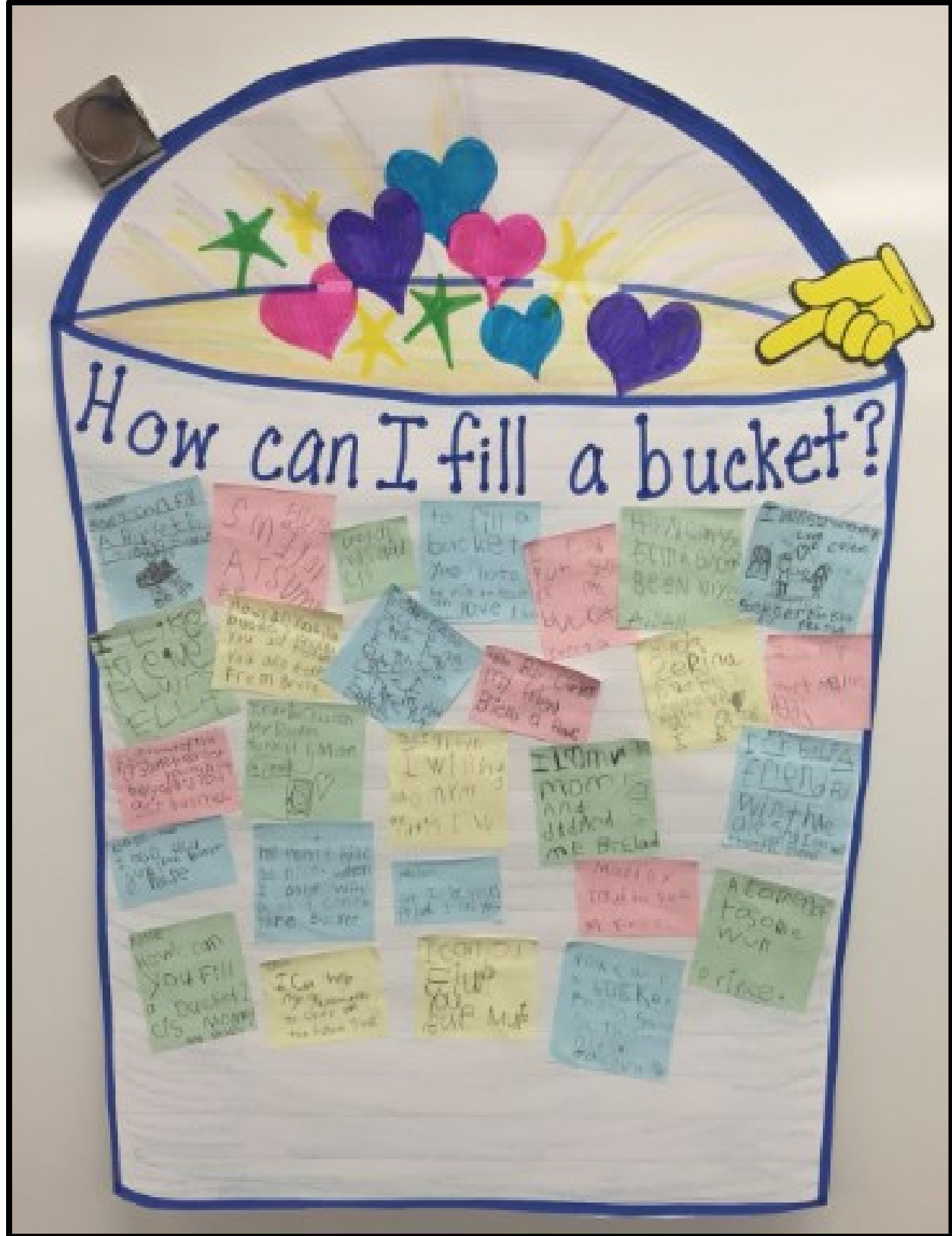

## BUCKET FILLERS



Cleans up when done working.



Is a good listener.



Does their best work.



Cheers for others.



Is kind to everyone.



Smiles.



Encourages others.



Focuses on learning.

## BUCKET DIPPERS



Pouts when doesn't get their way.



Throws a tantrum.



Does not share.



Hurts others.



Is disrespectful.



Makes fun of others.



Gets frustrated easily.



Distracts people from learning.





## Our Bucket Filler Pledge

We pledge to do our best to be bucket fillers each day, by being kind to others and watching what we say.

If we accidentally spill the bucket of a friend, we'll say we're sorry and be kind until their bucket is full again.





**SOURCE:**  
**THEPRIMARYPARADE.COM**



**SOURCE:**  
**LESSONS FOR LITTLE ONES**



# BE A BUCKET FILLER

*Cut out the good behavior choices and put them on the green bucket.  
Cut out the bad behavior choices and put them on the red bucket.*



GOOD CHOICES



BAD CHOICES





**FOR MORE INFORMATION OR TO DOWNLOAD OR SHARE  
THIS PRESENTATION  
GO TO: [WWW.KIDS4KIDS.ORG](http://WWW.KIDS4KIDS.ORG)**

786-942-6470 Teachkidskindness@gmail.com

 Home About Us Projects Kindness Matters Bracelets **Kindness 101: For Teachers** Contact [→ donate](#)

### Kindness 101: A Guide for Teachers

**Dear Kindness Educator,**

Kids 4 Kids teaches kids they can change the world through their acts of kindness. You can incorporate this into your school day or an afterschool club.

[TO LEARN MORE ABOUT OUR CLASSROOM PROGRAM MODEL CLICK HERE](#)

[Click here to download the Kindness 101 FLAAYC Conference Presentation](#)

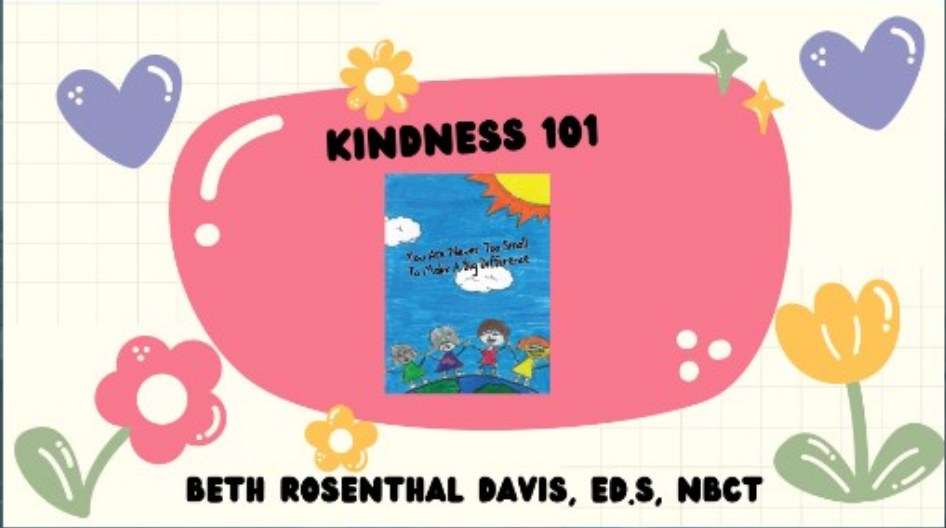

**BETH ROSENTHAL DAVIS, ED.S, NBCT**



**EMAIL:  
[TEACHKIDSKINDESS@GMAIL.COM](mailto:TEACHKIDSKINDESS@GMAIL.COM)**